

# **PRIMUS MODEL 643**

*Vertical Form Fill Seal Machine*



*By General Packaging Equipment Co.*

# PRIMUS BY GENERAL

**With today's economy you must maximize your productivity and minimize waste. The Primus 643 machine by General is designed to help you accomplish both goals in your packaging operation.**

## Features:

- High pressure seals
- Color touch screen interface with multiple language settings
- Easy adjustment of all operating timing functions and components
- Password protected memory
- Filler controls integrated into base machine controls
- Bag and case count with output case change
- Fault Indications
- Temperature indicators
- Optional Internet and LAN
- Multiple filler options

## Size Ranges:

### **Pillow Pack Size Range Width:**

Min.: 2.5" (64mm)

Max.: 14" (356mm)

### **Square Bottom Size Range:**

Min.: 2" (50mm) Face x 1.25" (32mm) Side

Max.: 9" (230mm) Face X 5" (127mm) Side

### **Length:**

Up to 22" (560mm) Long

**[Click here for a more in-depth look at this machine!](#)**



# PRIMUS DIMENSIONS WITH AUGER FILLER

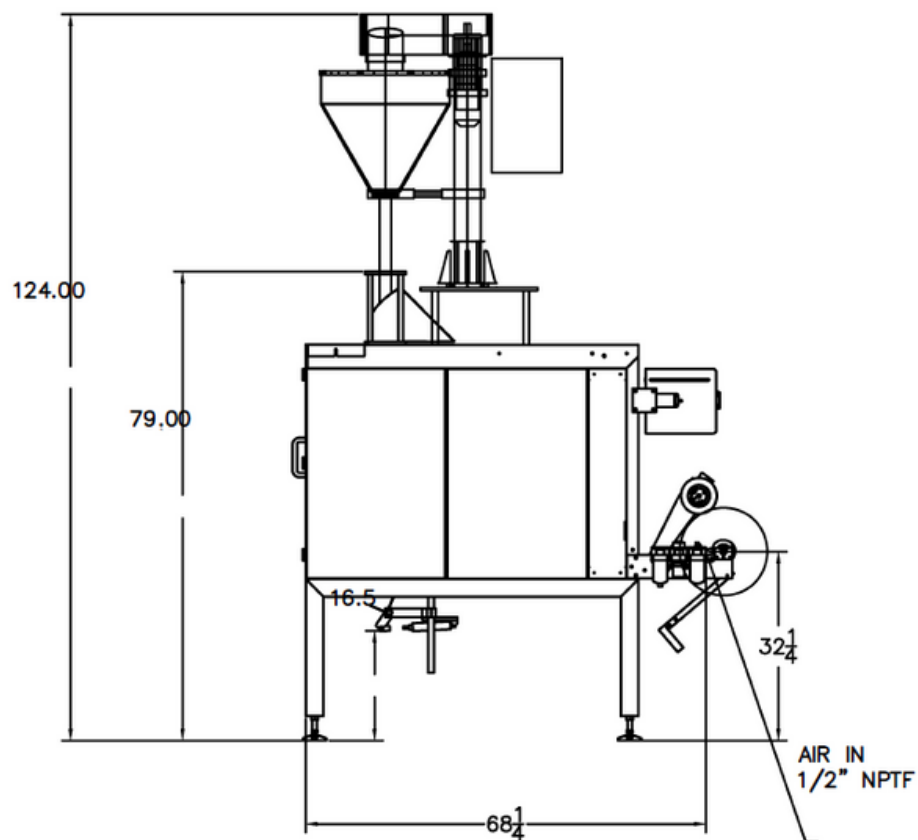

POWER IN  
220V 60HZ 3PH

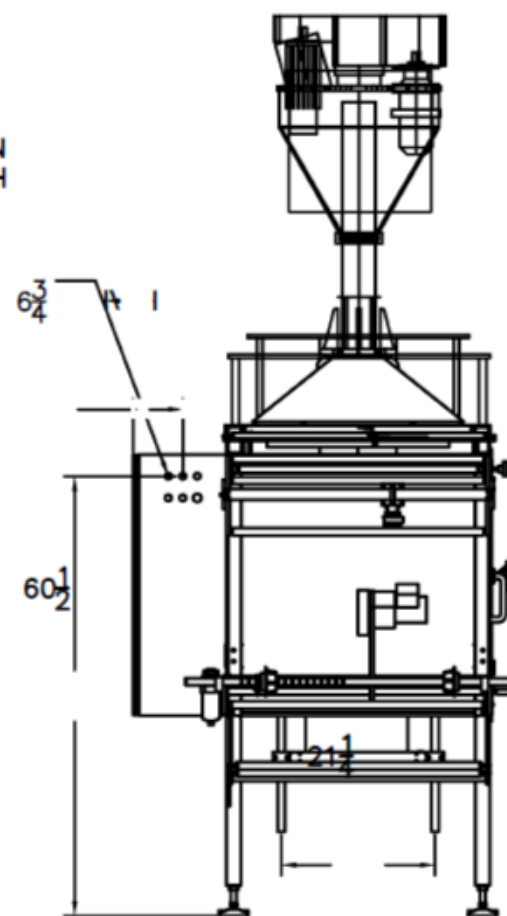

General Packaging Equipment Co.  
6048 Westview Dr. Houston, TX 77055  
Tel: (713)-686-4331  
[www.generalpackaging.com](http://www.generalpackaging.com)  
email: [sales@generalpackaging.com](mailto:sales@generalpackaging.com)